

# NHR 中空旋轉平台(可替換式伺服馬達) ROTATING PLATFORMS (Replace servo motor)



## 性能數據 Performance data

TYPE	NHR-85		NHR-130		NHR-200	
Model	42型步進馬達 42Type Stepping motor	100W AC 伺服馬達 100W AC Servo Motor	60型步進馬達 60Type Stepping motor	200~400W AC 伺服馬達 200~400W AC Servo Motor	85型步進馬達 85Type Stepping motor	750W AC 伺服馬達 750W AC Servo Motor
旋轉平台軸承 Bearings	交叉滾珠軸承 Crcss Roller bearing		交叉滾珠軸承 Crcss Roller bearing		交叉滾珠軸承 Crcss Roller bearing	
容許轉矩 Permissible torque	2.8 N · m		12 N · m		50 N · m	
慣性慣量 Moment of inertia	2330 x 10 <sup>-7</sup> kg.m <sup>2</sup>		9216 x 10 <sup>-6</sup> kg.m <sup>2</sup>		85792 x 10 <sup>-6</sup> kg.m <sup>2</sup>	
允許轉速 Permissible speed	200rpm(盤面 DISK)					
減速比 Speed reduction ratio	直結式減速機1:12 Direct-drive reducer 1:12					
定位精度 Positioning accuracy	≤3mins					
反覆定位精度 Repeatability	±15sec					
容許推力載重 Permissible thrust force	20kgf		300kgf		500kgf	
容許慣性載重 Permissible load of inertia	10N.m		60N.m		200N.m	
旋轉平台平行度 Parallelism of rotating table	±5μm					
旋轉平台同心度 Concentricity of rotating table	≈0.01mm					
保護等級 Protection class	40IP					
重量 Weight	1.1kg		2.6kg		9.4kg	

特殊規格歡迎來電洽詢訂製

Please contact us for inquiries regarding other Specifications.

**產品特性 Product Features**

工作物可直接鎖固 Direct mounting of workpiece  
 旋轉盤面可直接鎖固工作物，提升工作裝載之方便性  
 The rotating table allows for direct mounting of workpiece for  
 Added convenience in workpiece loading.

配線方便 Convenient wiring  
 此旋轉平台為中空設計，無論是配線或配管均方便  
 The rotating table is a hollow structure design, making it convenient for electric wiring or piping work.

高精度 High accuracy  
 定位精準度小於一分，重複精準度可達 + - 5  
 Positioning accuracy is less than 1 min.

運轉動作平穩 Stable rotating motion  
 盤面轉動平穩、順暢、且定位快速  
 The table rotation is stable and smooth as well as fast in positioning.

適用各種馬達 Suitable for various motors  
 中空旋轉平台可採用各種廠牌之伺服馬達或步進馬達驅動  
 The rotating table can be driven by various brands of servo motors or stepping motors.

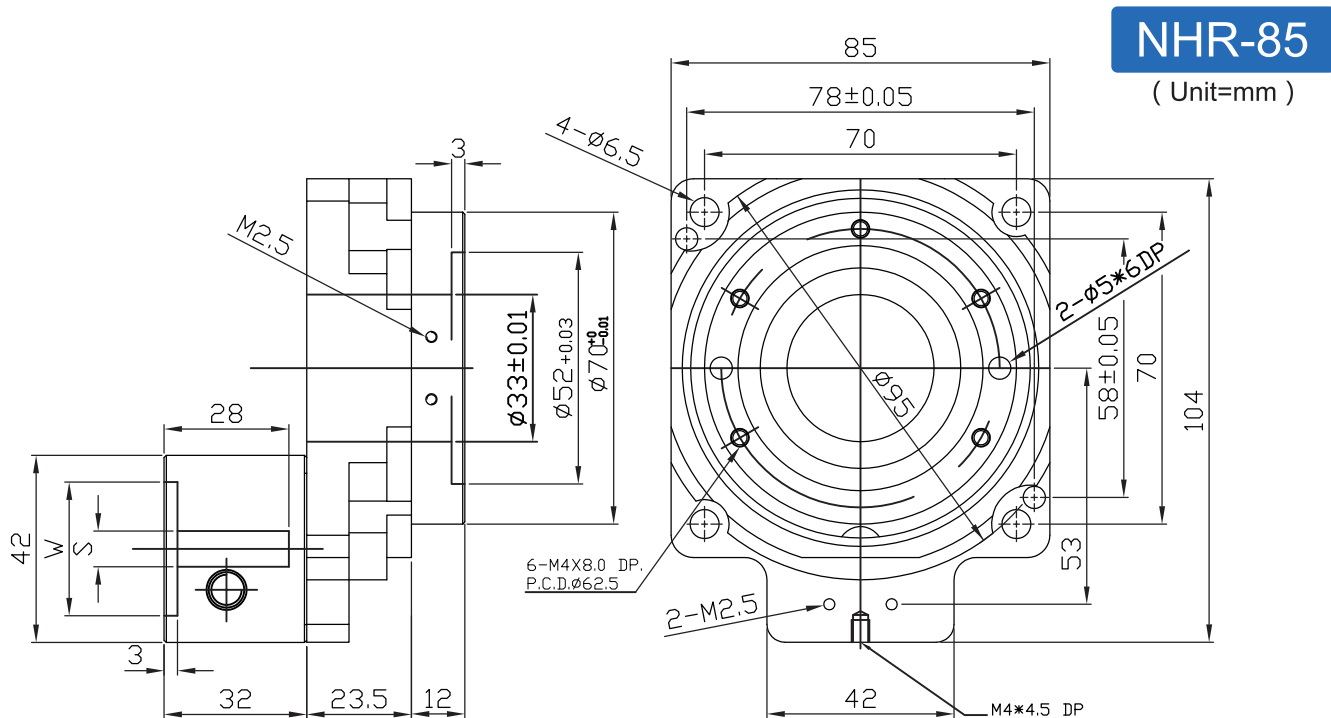

S, W 為馬達配合尺寸  
 S, W Size may according to motor flange chosen

NHR 中空旋轉平台(可替換式伺服馬達)  
 ROTATING PLATFORMS (Replace servo motor)



**NHR-130**

(Unit=mm)

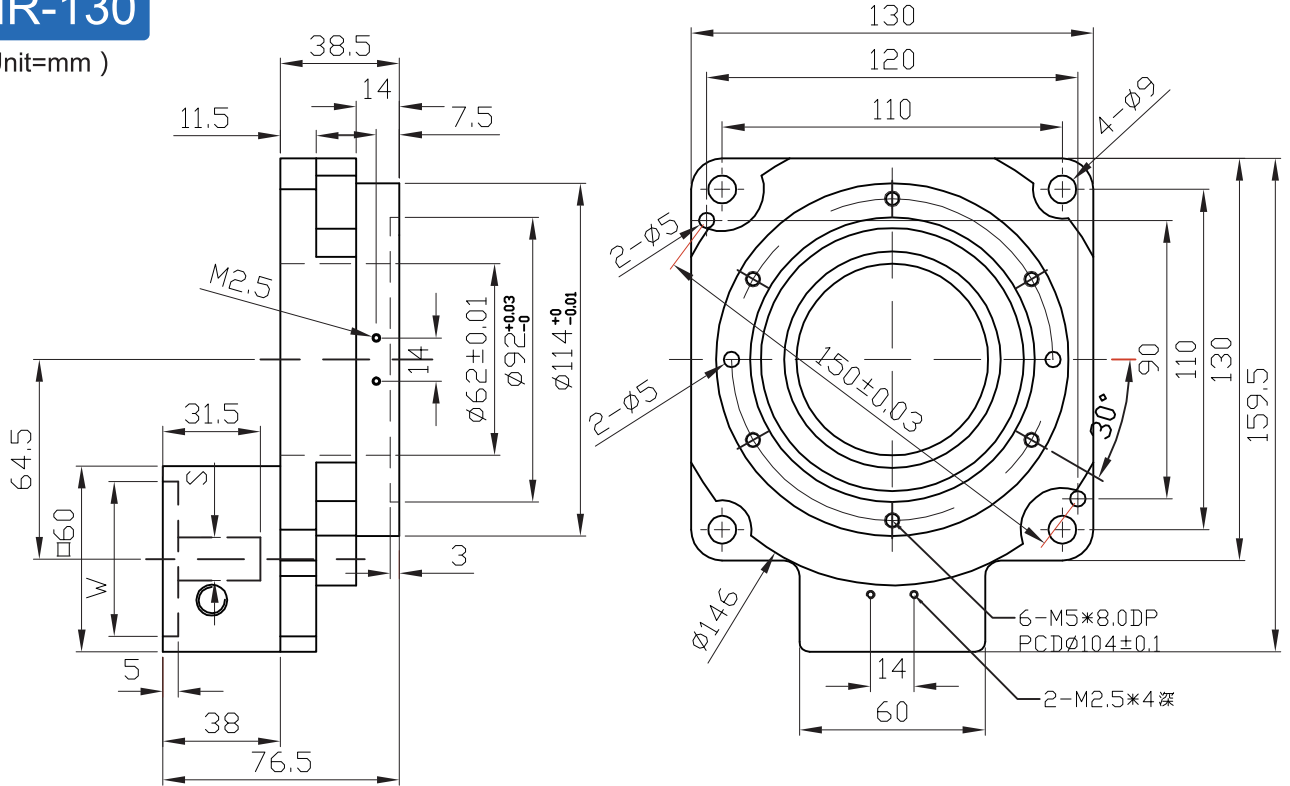

**NHR-200**

(Unit=mm)

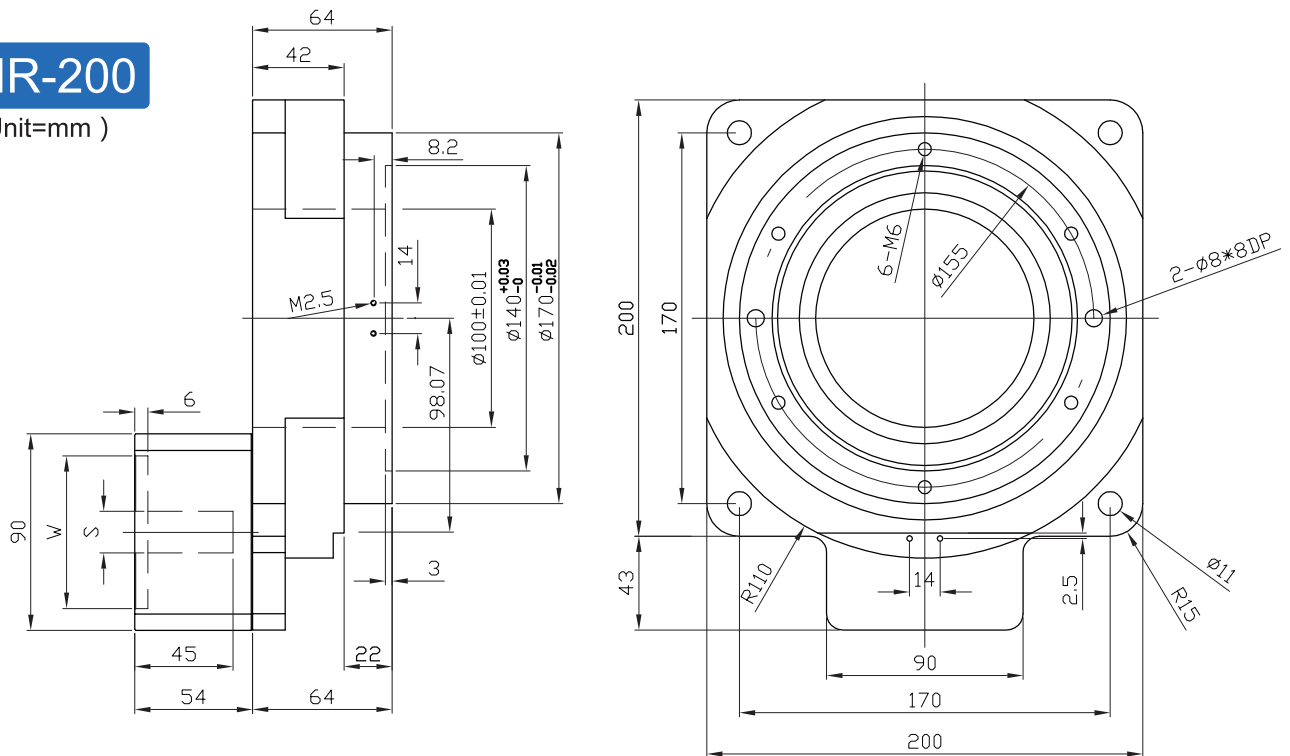

S, W 為馬達配合尺寸  
 S, W Size may according to motor flange chosen