

RA 系列直角型減速機

RA RIGHT-ANGLE REDUCERS



Ra系列採用傘型齒輪設計，背隙可以調整，精巧的外型可以搭配任何方向定位，安裝容易能配合多種馬達或加裝減速機。

RA series bevel gear can adjust backlash, compact housing design can be used with any orientation, Easy to install or retrofit can meet a variety of motor reducer.

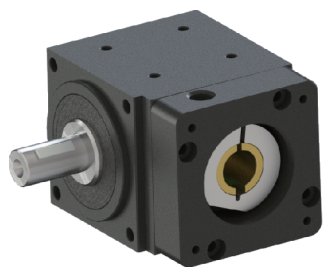

RAS(實心軸)

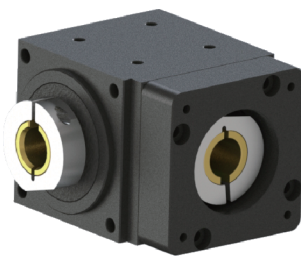

RAH(空心軸)

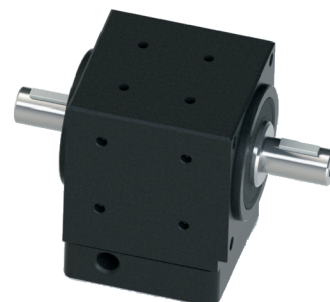

RAD(雙出力軸)

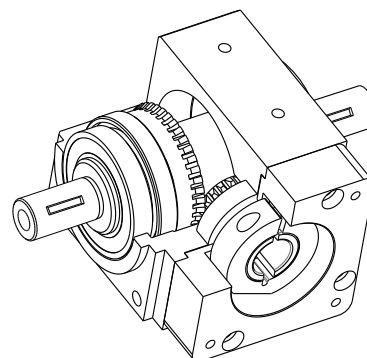
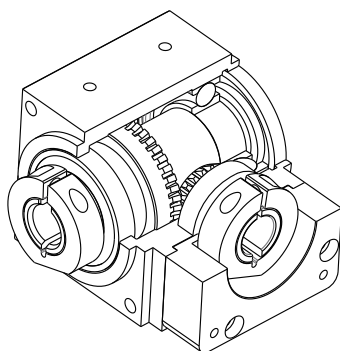
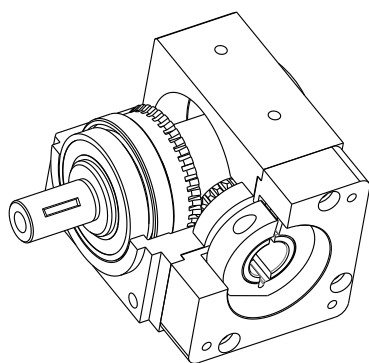

性能數據 Performance data

MODEL	UNIT	RA-42	RA-60	RA-90	RA-120	RA-150
外框尺寸 Size	mm	□42	□60	□90	□120	□142
額定出力軸轉矩 Rated Output torque	Nm	15	20	45	90	115
最大出力軸轉矩 Max.Output torque	Nm	額訂出力軸轉矩2倍 Rated Output torque x 2				
額定入力端馬達轉速 Rated Input Speed	rpm	1500	1000	1000	800	800
入力軸轉動慣量 Rotational inertia	Kg-cm ²	0.02	0.06	0.4	0.8	1.72
容許最大徑向負載 Max.Radial Force	N	300	500	1200	1600	2500
容許最大軸向負載 Max.Axial Force	N	150	200	500	1000	1800
扭轉剛性 Torsional stiffness	Nm/弧分	1.2	1.5	5	12	21
可選用減速比Ratio		2:1, 5:1	2:1, 5:1	2:1, 5:1	2:1	2:1, 5:1
重量 W	Kg	0.7	1.3	4.1	8.5	14

RA 系列直角型減速機 RA RIGHT-ANGLE REDUCERS



RAH

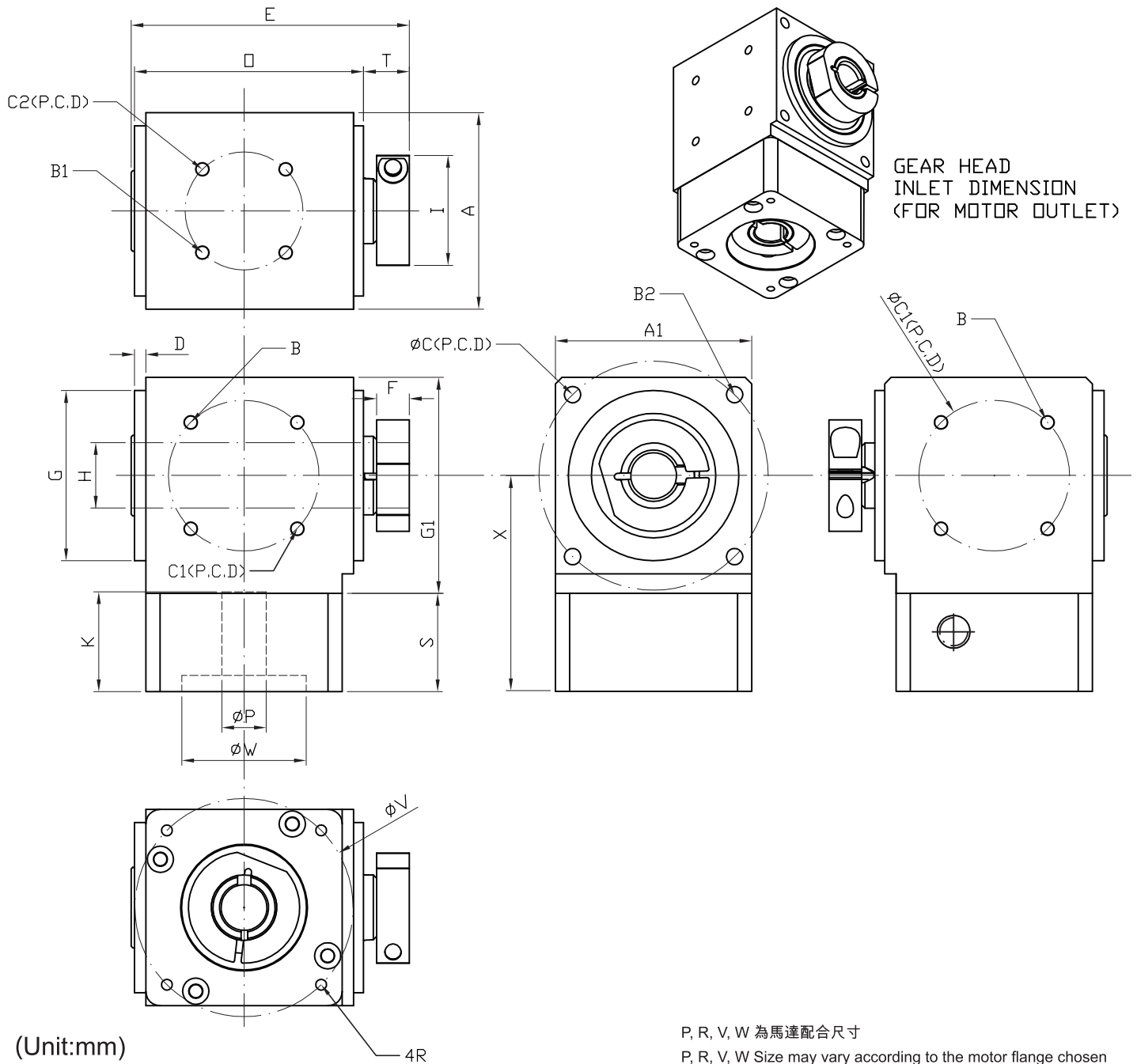

型號 \ 尺寸	A	A1	B	B1	B2	C	C1	C2	D	E	F	G	G1	H	I	K	O	S	T	X
RAH42-02	42.5	42.5	M3	M3	M3	46	42	35	3	66.5	10	36	62.3	12	28	27	47	15.5	12.5	41
RAH42-05	42.5	42.5	M3	M3	M3	46	42	35	3	66.5	10	36	74.8	12	28	27	47	28	12.5	53.5
RAH60-02	60	60	M4	M4	M5	70	46	36	3	84.2	10.5	52	83.2	14	34	32	63.5	17.2	13.2	53.2
RAH60-05	60	60	M4	M4	M5	70	46	36	3	85	10.5	52	93.7	14	34	30	63.5	27.7	14	63.8
RAH90-02	90	90	M5	M5	M6	100	70	60	5	122.7	14	80	128.7	20	48	52	92	31.7	20	83.7
RAH90-05	90	90	M5	M5	M6	100	70	60	5	124.5	14	80	138.5	20	48	46	92	41.5	22	93.5
RAH120-02	116	116	M8	M8	M8	145	113.14	113.14	4	150	20	110	162	25	63	60	116	45	24	104

RA 系列直角型減速機 RA RIGHT-ANGLE REDUCERS



RAD

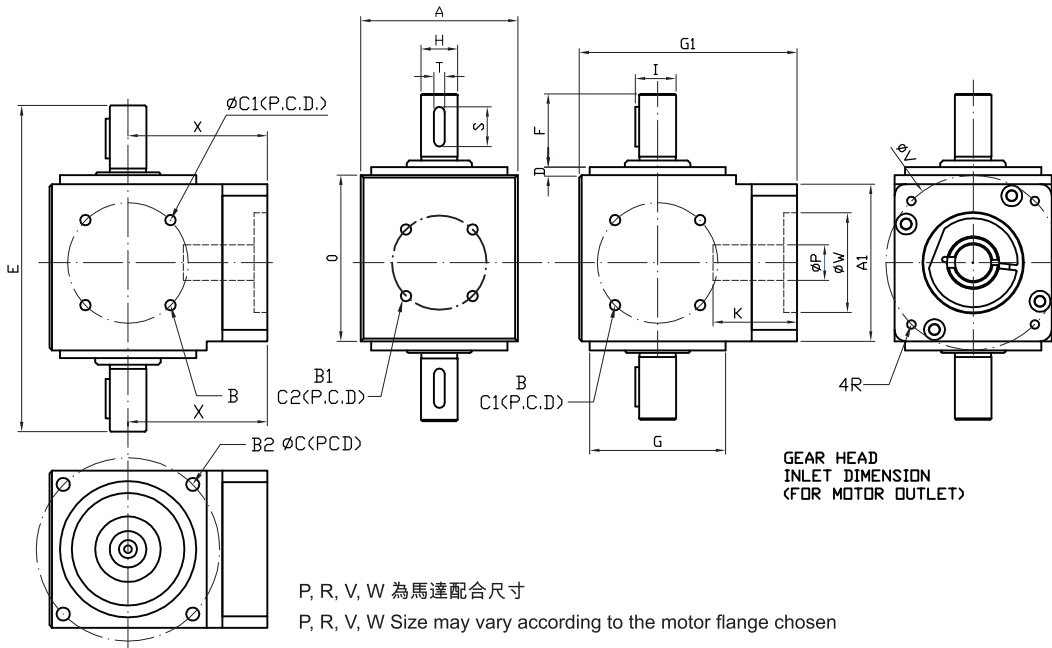

(Unit:mm)

型號 \ 尺寸	A	A1	B	B1	B2	C	C1	C2	D	E	F	G	G1	H	I	K	O	S	T	X
RAD42-02	42.5	42.5	M3	M3	M3	48	42	35	3	97	10	36	62.3	12	28	27	47	15.5	4	41
RAD42-05	42.5	42.5	M3	M3	M3	48	42	35	3	97	10	36	74.8	12	28	27	47	28	4	53.5
RAD60-02	60	60	M4	M4	M5	70	46	36	3	125	27	52	83.2	14	15.5	32	63.5	15	4	53.2
RAD60-05	60	60	M4	M4	M5	70	46	36	3	125	27	52	93.7	14	15.5	32	63.5	15	4	63.8
RAD90-02	90	90	M5	M5	M6	100	70	60	5	189	46	80	128.7	20	22.5	52	92	25	6	83.7
RAD90-05	90	90	M5	M5	M6	100	70	60	5	189	46	80	138.5	20	22.5	46	92	25	6	93.5
RAS120-02	116	116	M8	M8	M8	145	113.14	113.14	4	218	46	110	162	25	28	60	116	30	8	104
RAS150-02	142	142	M10	M10	M10	165	130	115	4	313.5	73.5	130	206	40	44.5	60	154	50	10	134

RAS

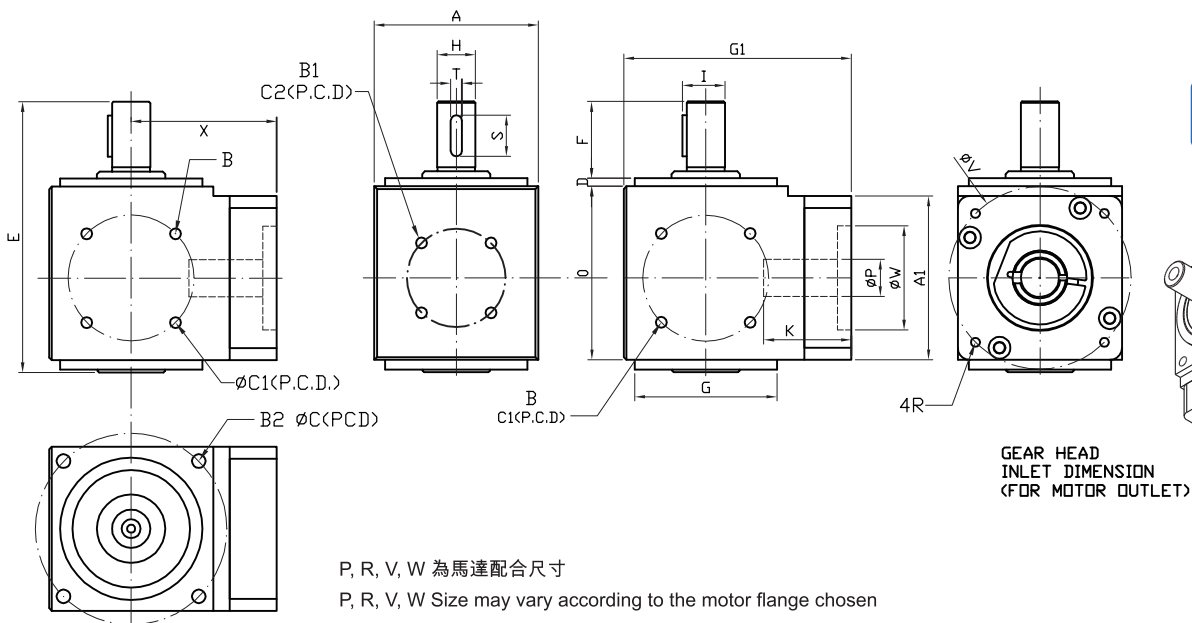

(Unit:mm)

型號 \ 尺寸	A	A1	B	B1	B2	C	C1	C2	D	E	F	G	G1	H	I	K	O	S	T	X
RAS42-02	42.5	42.5	M3	M3	M3	48	42	35	3	75.5	10	36	62.3	12	28	27	47	15.5	4	41
RAS42-05	42.5	42.5	M3	M3	M3	48	42	35	3	75.5	10	36	74.8	12	28	27	47	28	4	53.5
RAS60-02	60	60	M4	M4	M5	70	46	36	3	99	28	52	83.2	14	15.5	30	63.5	15	4	53.2
RAS60-05	60	60	M4	M4	M5	70	46	36	3	98.5	27.3	52	93.7	14	15.5	30	63.5	15	4	63.8
RAS90-02	90	90	M5	M5	M6	100	70	60	5	145	42	80	128.7	20	22.5	52	92	25	6	83.7
RAS90-05	90	90	M5	M5	M6	100	70	60	5	149	46	80	138.5	20	22.5	46	92	25	6	93.5
RAS120-02	116	116	M8	M8	M8	145	113.14	113.14	4	172	46	110	162	25	28	60	116	30	8	104
RAS150-02	142	142	M10	M10	M10	165	130	115	4	240	73.5	130	206	40	44.5	60	154	50	10	134